



**CESAB**

**spec sheet**

# CESAB B400

**1.6 - 2.0 tonne**  
2022 model

4-Wheel 48V  
Electric counterbalanced trucks



**ZERO**  
emissions

# CESAB B416 – B420L

## Truck Specifications

CHARACTERISTICS								
1.1	Manufacturer		CESAB	CESAB	CESAB	CESAB	CESAB	
1.2	Model designation		B416-II	B416L-II	B418L-II	B420-II	B420L-II	
1.3	Power unit		Electric	Electric	Electric	Electric	Electric	
1.4	Operation		Driver seated	Driver seated	Driver seated	Driver seated	Driver seated	
1.5	Load capacity	Q	[t]	1,6	1,6	1,8	1,8	2,0
1.6	Load centre distance	c	[mm]	500	500	500	500	500
1.8	Load distance, centre of drive axle to fork face	x	[mm]	317	317	317	317	317
1.9	Wheelbase	y	[mm]	1453	1561	1561	1453	1561
WEIGHT								
2.1	Service weight (battery included)		[kg]	2952	2973	3071	3274	3261
2.2	Axle load, with load, front/rear		[kg]	4056/496	4077/496	4368/503	4661/613	4708/553
2.3	Axle load, without load, front/rear		[kg]	1500/1452	1586/1387	1573/1498	1480/1794	1609/1652
WHEELS AND TYRES								
3.1	Tyres: P=Pneumatic, SE=Superelastic, C=Cushion, G=Twin tyre			SE	SE	SE	SE	SE
3.2	Tyre size front			18x7-8	18x7-8	18x7-8	200/50-10	200/50-10
3.3	Tyre size rear			16x6-8	16x6-8	16x6-8	16x6-8	16x6-8
3.5	Wheels, number front/rear (x = driven)			2x/2	2x/2	2x/2	2x/2	2x/2
3.6	Track width front	b10	[mm]	905	905	905	925	925
3.7	Track width, rear	b11	[mm]	880	880	880	880	880
DIMENSIONS								
4.1	Mast/fork tilt forward/backward	$\alpha/\beta$	[°]	5/7	5/7	5/7	5/7	5/7
4.2	Height, mast lowered	$h_1$	[mm]	2120	2120	2120	2120	2120
4.3	Free lift	$h_2$	[mm]	115	115	115	115	115
4.4	Lift	$h_3$	[mm]	3300	3300	3300	3300	3300
	Lift height	$h_{23}$	[mm]	3335	3335	3335	3335	3335
4.5	Height, mast extended	$h_4$	[mm]	3870	3870	3870	3870	3870
4.7	Height of overhead guard (cab)	$h_6$	[mm]	2055	2055	2055	2055	2055
4.8	Seat height	$h_7$	[mm]	1051	1051	1051	1051	1059
4.12	Coupling height	$h_{10}$	[mm]	427	427	427	427	427
4.19	Overall length	$l_1$	[mm]	3014	3122	3122	3044	3122
4.20	Length to face of forks	$l_2$	[mm]	2014	2122	2122	2044	2122
4.21	Overall width	$b_1$	[mm]	1060	1060	1060	1152	1152
4.22	Fork dimensions	s/e/l	[mm]	35x100x1000	35x100x1000	35x100x1000	35x120x1000	35x120x1000
4.23	Fork carriage DIN 15 173, class/type A, B			II-A	II-A	II-A	II-A	II-A
4.24	Fork carriage width	$b_3$	[mm]	920	920	920	920	920
4.31	Ground clearance, with load, below mast	$m_1$	[mm]	80	80	80	90	90
4.32	Ground clearance, centre of wheelbase	$m_2$	[mm]	101	101	101	107	107
4.33	Aisle width, pallets 1000x1200 crossways	$A_{st}$	[mm]	3327	3438	3438	3357	3438
4.34	Aisle width, pallets 800x1200 lengthways	$A_{st}$	[mm]	3460	3568	3568	3490	3568
4.35	Turning radius	$W_a$	[mm]	1707	1811	1811	1737	1811
4.36	Internal turning radius	$b_{13}$	[mm]	68	49	49	68	49
PERFORMANCE								
5.1	Travel speed, with/without load		[km/h]	20,0/20,0	20,0/20,0	20,0/20,0	20,0/20,0	20,0/20,0
5.2	Lift speed, with/without load		[m/s]	0,43/0,61	0,43/0,61	0,42/0,61	0,38/0,54	0,38/0,54
5.3	Lowering speed, with/without load		[m/s]	0,55/0,53	0,55/0,53	0,55/0,53	0,52/0,50	0,52/0,50
5.5	Drawbar pull, with/without load		[N]	5083/5171	4998/5143	4998/5143	4851/5055	4851/5055
5.6	Max. drawbar pull, with/without load		[N]	9534/9437	9448/9409	9448/9409	9157/9197	9157/9197
5.7	Gradeability, with/without load		[%]	17,3/22,4	15,3/24,2	15,3/24,2	13,4/24,6	13,4/24,6
5.8	Max. gradeability, with/without load		[%]	23,6/22,4	21,0/24,2	21,0/24,2	18,3/24,6	18,3/24,6
5.9	Acceleration time, with/without load		[s]	4,6/4,2	4,6/4,2	4,7/4,3	4,7/4,3	4,7/4,3
5.10	Service brake			hydraulic	hydraulic	hydraulic	hydraulic	hydraulic
ELECTRIC MOTORS								
6.1	Drive motor, rating S2 60 min.		[kW]	6,0x2	6,0x2	6,0x2	6,0x2	6,0x2
6.2	Lift motor, rating S3 15%		[kW]	11,7	11,7	11,7	11,7	11,7
6.3	Battery according to DIN 43 531/35/36, A, B, C, no			DIN 43531A	DIN 43531A	DIN 43531A	DIN 43531A	DIN 43531A
6.4	Battery voltage, nominal capacity $K_s$		[V/Ah]	48/550	48/660	48/660	48/550	48/660
6.5	Battery weight		[kg]	856	1013	1013	856	1013
6.6	Energy consumption acc. to EN16796:2016		[kWh/h]	4,5	4,5	4,8	5,1	5,1
OTHERS								
8.1	Type of drive control			inverter MOSFET	inverter MOSFET	inverter MOSFET	inverter MOSFET	inverter MOSFET
8.2	Operating pressure for attachments		[bar]	183	183	183	183	183
8.3	Oil flow for attachments		[l/min]	41,3	41,3	41,3	41,3	41,3
8.4	Sound level at driver's ear acc. To EN 12 053		[dB(A)]	71,5	71,5	71,5	71,5	71,5

Note: unless otherwise specified, all data refer to vehicles with SE tyres. All performance figures refer to fully run-in vehicles, in perfect working status with homologated tyres mix. Truck performance and dimensions are nominal and subject to tolerances.

# CESAB B416 - B420L

## Dimensional Drawings

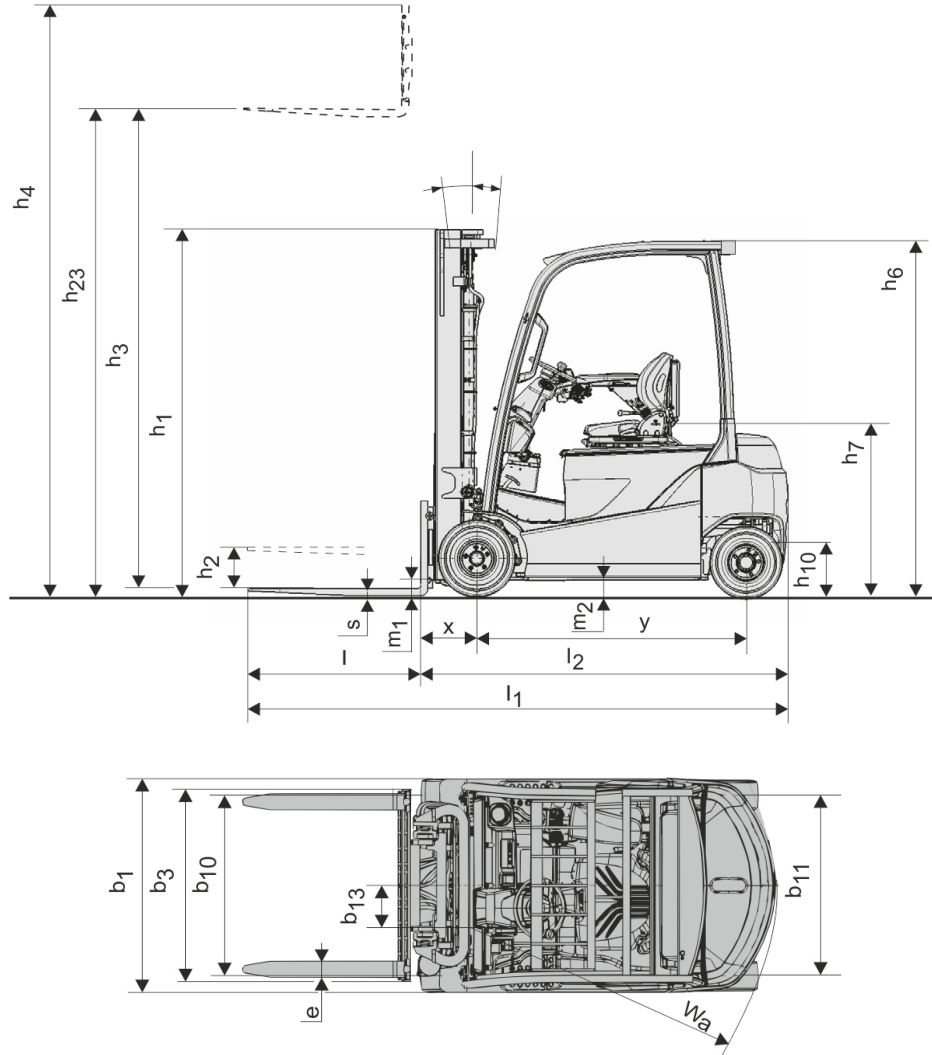

The data in this specification sheet was determined based on our standard testing conditions. Operating performance may vary depending on the actual specification and condition of the truck as well as the condition of the operating area. Availability and specifications are determined regionally and are subject to change without notice. Please consult your authorised CESAB dealership for further details.

### Mast Specifications

	Duplex NFL (IMD)								Duplex FFL (Std.) <sup>*</sup>				Duplex FFL (IMD)				Triplex FFL (Std.) <sup>*</sup>				Triplex FFL (IMD)										
<b>B416 - B420L</b>	$h_{23}$	3035	3335	3535	3735	4035	4535	5035	3035	3335	3535	3735	3035	3335	3535	3735	4335	4535	4735	5035	5535	6035	4335	4535	4735	5035	5535	6035	6535	7035	7535
	$h_3$	3000	3300	3500	3700	4000	4500	5000	3000	3300	3500	3700	3000	3300	3500	3700	4300	4500	4700	5000	5500	6000	4300	4500	4700	5000	5500	6000	6500	7000	7500
	$h_1$	1970	2120	2220	2380	2570	2820	3070	1970	2120	2220	2380	2000	2150	2250	2350	1970	2040	2120	2220	2380	2570	1980	2050	2150	2250	2450	2600	2800	3000	3200
	$h_4$	3570	3870	4070	4270	4570	5070	5570	3580	3880	4080	4280	3555	3855	4055	4255	4845	5045	5245	5545	6045	6545	4845	5045	5245	5545	6045	6545	7045	7545	8045
		4260	4560	4760	4960	5260	5760	6260	4260	4560	4760	4960	4260	4560	4760	4960	5560	5760	5960	6260	6760	7260	5560	5760	5960	6260	6760	7260	7760	8260	8760
	$h_2$	80	80	80	80	80	80	80	1430	1580	1680	1840	1440	1590	1690	1790	1460	1530	1610	1710	1870	2060	1430	1500	1600	1700	1900	2050	2250	2450	2650
		80	80	80	80	80	80	80	745	895	995	1155	735	885	985	1085	745	815	895	995	1155	1345	715	785	885	985	1185	1335	1535	1735	1935
	Tilt, forward/backward	5/7(5)**								5/7(5)**				5/7(5)**				5/7(5)**				5/5									

<sup>\*</sup>) Standard masts with central free lift cylinder  
<sup>\*\*</sup>) Data in ( ) are for trucks with cabin or front windshield  
<sup>1</sup>) without load backrest  
<sup>2</sup>) with std. load backrest 1220 mm





[www.cesab-forklifts.eu](http://www.cesab-forklifts.eu)



Your authorised CESAB dealer



Pictures may show optional equipment and accessories not included in the standard execution of the truck.

The data in this specification sheet was determined based on our standard testing conditions. Operating performance may vary depending on the actual specification and condition of the truck as well as the condition of the operating area.

Availability and specifications are determined regionally and are subject to change without notice. Please consult your authorised CESAB dealership for further details.  
SPEC\_B400\_EN\_202202 / Ucan V02 – Copyright CESAB Material Handling Europe.

