



**CESAB**

**spec sheet**

# CESAB R200

**1.4 - 1.6 tonne**

Reach Trucks

Publication: 2022



# CESAB R214 - R216

## Truck Specifications (2021 Model)

CHARACTERISTICS					
1.1	Manufacturer		CESAB	CESAB	
1.2	Model		R214	R216	
1.3	Drive		Electric	Electric	
1.4	Operator type		Seated	Seated	
1.5	Load capacity/rated load	Q	[kg]	1400	1600
1.6	Load centre	c	[mm]	600	600
1.8	Load distance, centre of support arm wheel to face of forks	x	[mm]	341*	341*
1.9	Wheelbase	y	[mm]	1342	1342
WEIGHT					
2.1	Service weight including battery		[kg]	3190	3190
2.3	Axle load, mast retracted without load, drive/support arm wheel		[kg]	1953/1237	1953/1237
2.4	Axle load, mast extended with load, drive/support arm wheel		[kg]	575/4011	453/4332
2.5	Axle load, mast retracted with load, drive/support arm wheel		[kg]	1627/2960	1568/3219
WHEELS					
3.1	Drive/support arm wheel		[mm]	Polyurethane	Polyurethane
3.2	Wheel size, front		[mm]	Ø 343x140	Ø 343x140
3.3	Wheel size, rear		[mm]	Ø 250x85	Ø 250/85
3.5	Wheels, number front/rear (x=driven wheels)			1x/2	1x/2
3.7	Track width, rear	bll	[mm]	988	988
DIMENSIONS					
4.1	Tilt of fork, forward/backward	$\alpha/\beta$	[deg]	-2°/4°*	-2°/4°*
4.2	Height, mast lowered	$h_1$	[mm]	2887*	2887*
4.3	Free lift	$h_2$	[mm]	2403*	2403*
4.4	Lift	$h_3$	[mm]	6945*	6945*
	Lift height	$h_{23}$	[mm]	7000*	7000*
4.5	Height, mast extended	$h_4$	[mm]	7540*	7540*
4.7	Height of overhead guard (cab)	$h_6$	[mm]	2198	2198
4.8	Seat height	$h_7$	[mm]	1136	1136
4.10	Height of support arms	$h_8$	[mm]	270	270
4.15	Height of lowered forks	$h_{13}$	[mm]	55	55
4.19	Overall length	$l_1$	[mm]	2413	2413
4.20	Length to face of forks	$l_2$	[mm]	1263	1263
4.21	Overall width	$b_1$	[mm]	1120	1120
4.22	Fork dimensions	s/e/l	[mm]	40/100/1150*	40/100/1150*
4.23	Fork carriage ISO 2328, class/type A, B			II A	II A
4.24	Fork carriage width	$b_3$	[mm]	819	819
4.25	Width over forks	$b_5$	[mm]	252-698	252-698
4.26	Distance between support arms	$b_4$	[mm]	900	900
4.28	Reach distance	$l_4$	[mm]	503*	503*
4.31	Ground clearance, with load, below mast	$m_1$	[mm]	68	68
4.32	Ground clearance, centre of wheelbase	$m_2$	[mm]	74	74
4.33	Aisle width for pallets 1000 x 1200 crossways (VDI 2012)	$A_{st}$	[mm]	2695	2695
4.34	Aisle width for pallets 800 x 1200 lengthways (VDI 2012)	$A_{st}$	[mm]	2751	2751
4.35	Turning radius	$W_o$	[mm]	1604	1604
4.37	Length across support arms	$l_7$	[mm]	1747	1747
PERFORMANCE DATA					
5.1	Travel speed, with/without load		[km/h]	10/11	10/11
5.2	Lift speed, with/without load		[m/s]	0,38/0,68	0,36/0,68
	Lift speed, with/without load (High speed version) <sup>1)</sup>		[m/s]	0,57/0,92	0,52/0,92
5.3	Lowering speed, with/without load		[m/s]	0,59/0,55	0,59/0,55
5.4	Reach speed, with/without load		[m/s]	0,20/0,28	0,20/0,28
5.8	Max. gradeability, with/without load <sup>2)</sup>		[%]	10/15	10/15
5.9	Acceleration time with/without load (over 10 m)		[s]	4,9/4,6	5,0/4,6
5.10	Service brake			Electric	Electric
ELECTRIC MOTOR					
6.1	Drive motor rating S2 60 min		[kW]	9.0	9.0
6.2	Lift motor rating S3 15%		[kW]	11.0	11.0
	Lift motor rating S3 15% (High speed version)		[kW]	15.0	15.0
6.4	Battery voltage, nominal capacity $K_s$		[V/Ah]	48/310*	48/310*
6.5	Battery weight		[kg]	510	510
6.6	Energy consumption acc to EN16796		[kWh/h]	TBA	2,46
6.7	Turnover output		[t/h]	TBA	66,5
6.8	Energy consumption at turnover output		[kWh/h]	TBA	2,58
OTHERS					
8.1	Type of drive control			Variable AC	Variable AC
8.2	Sound level at the driver's ear according to EN 12 053		[dB(A)]	64	64

<sup>1)</sup> Not in combination with 310 Ah lead-acid battery <sup>2)</sup> Measured according to company standard

<sup>3)</sup> Other alternatives are available

All data are based on table configuration. Other configurations may give other values. Truck performance and dimensions are nominal and subject to tolerances. Products and specifications are subject to change without notice.



1.4 - 1.6 tonne

# CESAB R214 - R216

## Dimensional Drawings (2021 Model)

### Battery compartments

DIMENSIONS				R214			R216		
Battery compartment depth		[mm]		275	347	419	275	347	419
1.8	Load distance, centre of support arm wheel to face of forks	x	[mm]	341 <sup>1)</sup>	269 <sup>1)</sup>	190	341 <sup>1)</sup>	269 <sup>1)</sup>	190
4.20	Length to face of forks	$l_2$	[mm]	1263 <sup>2)</sup>	1335 <sup>2)</sup>	1425	1263 <sup>2)</sup>	1335 <sup>2)</sup>	1425
4.33	Aisle width for pallets 1000x1200 crossways	$A_{st}$	[mm]	2695 <sup>2)</sup>	2750 <sup>2)</sup>	2812	2695 <sup>2)</sup>	2750 <sup>2)</sup>	2812
4.34	Aisle width for pallets 800x1200 lengthways	$A_{st}$	[mm]	2751 <sup>2)</sup>	2817 <sup>2)</sup>	2890	2751 <sup>2)</sup>	2817 <sup>2)</sup>	2890
4.35	Turning Radius	$W_a$	[mm]	1604	1604	1604	1604	1604	1604
6.4	Battery voltage, nominal capacity $K_6$ Lead-acid		[V/Ah]	48/310	48/465	48/620	48/310	48/465	48/620
	Battery voltage, nominal capacity $K_6$ Li-ion		[V/Ah]	...	48/300-420	48/300-420	...	48/300-420	48/300-420
6.5	Battery weight, min.—max.		[kg]	510-609	685-825	875-1030	510-609	685-825	875-1030

<sup>1)</sup> With battery in sleigh - 9 mm <sup>2)</sup> With battery in sleigh + 9 mm

### Mast Dimensions

CESAB R214/216		TRIPLEX FULL FREELIFT A												
Lift height	$h_{23}$	[mm]	4900	5400	5700	6300	7000	7250	7500	8000	8500	9000	9500	10000
4.4	Lift	$h_3$	[mm]	4845	5345	5645	6245	6945	7195	7445	7945	8445	8945	9445
4.2	Height, mast lowered	$h_1$	[mm]	2187	2354	2454	2654	2887	2971	3054	3221	3387	3554	3721
4.3	Free lift	$h_2$	[mm]	1703	1871	1971	2171	2403	2487	2571	2737	2903	3071	3237
4.5	Height, mast extended	$h_4$	[mm]	5440	5941	6241	6841	7540	7792	8041	8542	9040	9541	10042

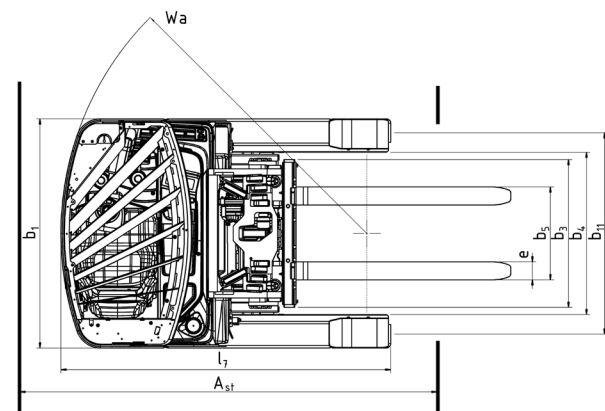
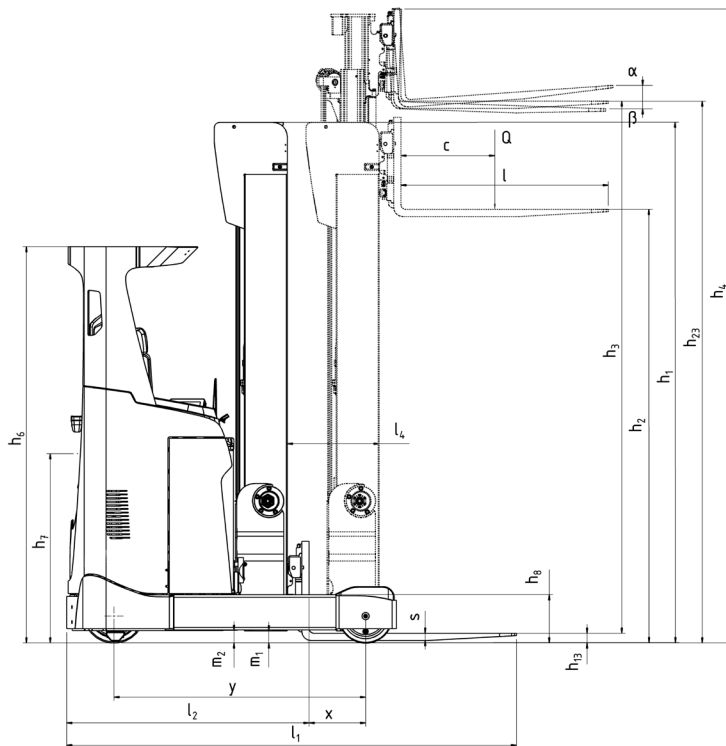

# CESAB R214 – R216, Coldstore versions

## Truck Specifications (2021 Model)

CHARACTERISTICS							
1.1	Manufacturer		CESAB	CESAB	CESAB	CESAB	
1.2	Model		R214	R214	R216	R216	
	Special execution		Coldstore	Coldstore	Coldstore	Coldstore	
	With or without cabin		Without cabin	With cabin	Without cabin	With cabin	
1.3	Drive		Electric	Electric	Electric	Electric	
1.4	Operator type		Seated	Seated	Seated	Seated	
1.5	Load capacity/rated load	Q	[kg]	1400	1400	1600	1600
1.6	Load centre	c	[mm]	600	600	600	600
1.8	Load distance, centre of support arm wheel to face of forks	x	[mm]	341*	260*	341*	260*
1.9	Wheelbase	y	[mm]	1342	1342	1342	1342
WEIGHT							
2.1	Service weight including battery		[kg]	3190	3473	3190	3473
2.3	Axle load, mast retracted without load, drive/support arm wheel		[kg]	1953/1237	2077/1396	1953/1237	2077/1396
2.4	Axle load, mast extended with load, drive/support arm wheel		[kg]	575/4011	784/4086	453/4332	801/4269
2.5	Axle load, mast retracted with load, drive/support arm wheel		[kg]	1627/2960	1692/3179	1568/3219	1626/3444
WHEELS							
3.1	Drive/support arm wheel		[mm]	Polyurethane	Polyurethane	Polyurethane	Polyurethane
3.2	Wheel size, front		[mm]	Ø 343x140	Ø 343x140	Ø 343x140	Ø 343x140
3.3	Wheel size, rear		[mm]	Ø 250x85	Ø 250/85	Ø 250x85	Ø 250/85
3.5	Wheels, number front/rear (x=driven wheels)			1x/2	1x/2	1x/2	1x/2
3.7	Track width, rear	bll	[mm]	988	988	988	988
DIMENSIONS							
4.1	Tilt of fork, forward/backward	$\alpha/\beta$	[deg]	-2°/4°*	-2°/4°*	-2°/4°*	-2°/4°*
4.2	Height, mast lowered	$h_1$	[mm]	2887*	2887*	2887*	2887*
4.3	Free lift	$h_2$	[mm]	2403*	2403*	2403*	2403*
4.4	Lift	$h_3$	[mm]	6945*	6945*	6945*	6945*
	Lift height	$h_{23}$	[mm]	7000*	7000*	7000*	7000*
4.5	Height, mast extended	$h_4$	[mm]	7540*	7540*	7540*	7540*
4.7	Height of overhead guard (cab)	$h_6$	[mm]	2198	2200	2198	2200
4.8	Seat height	$h_7$	[mm]	1136	1136	1136	1136
4.10	Height of support arms	$h_8$	[mm]	270	270	270	270
4.15	Height of lowered forks	$h_{13}$	[mm]	55	55	55	55
4.19	Overall length	$l_1$	[mm]	2413	2557	2413	2557
4.20	Length to face of forks	$l_2$	[mm]	1263	1407	1263	1407
4.21	Overall width	$b_1$	[mm]	1120	1120	1120	1120
4.22	Fork dimensions	s/e/l	[mm]	40/100/1150*	40/100/1150*	40/100/1150*	40/100/1150*
4.23	Fork carriage ISO 2328, class/type A, B			II A	II A	II A	II A
4.24	Fork carriage width	$b_3$	[mm]	819	819	819	819
4.25	Width over forks	$b_5$	[mm]	252-698	252-698	252-698	252-698
4.26	Distance between support arms	$b_4$	[mm]	900	900	900	900
4.28	Reach distance	$l_4$	[mm]	503*	431*	503*	431*
4.31	Ground clearance, with load, below mast	$m_1$	[mm]	68	68	68	68
4.32	Ground clearance, centre of wheelbase	$m_2$	[mm]	74	74	74	74
4.33	Aisle width for pallets 1000 x 1200 crossways (VDI 2012)	$A_{st}$	[mm]	2695	2820	2695	2820
4.34	Aisle width for pallets 800 x 1200 lengthways (VDI 2012)	$A_{st}$	[mm]	2751	2889	2751	2889
4.35	Turning radius	$W_o$	[mm]	1604	1667	1604	1667
4.37	Length across support arms	$l_7$	[mm]	1747	1810	1747	1810
PERFORMANCE DATA							
5.1	Travel speed, with/without load		[km/h]	10/11	10/11	10/11	10/11
5.2	Lift speed, with/without load		[m/s]	0,38/0,68	0,38/0,68	0,36/0,68	0,36/0,68
	Lift speed, with/without load (High speed version) <sup>1)</sup>		[m/s]	0,57/0,92	0,57/0,92	0,52/0,92	0,52/0,92
5.3	Lowering speed, with/without load		[m/s]	0,59/0,55	0,59/0,55	0,59/0,55	0,59/0,55
5.4	Reach speed, with/without load		[m/s]	0,20/0,28	0,20/0,28	0,20/0,28	0,20/0,28
5.8	Max. gradeability, with/without load <sup>2)</sup>		[%]	10/15	10/15	10/15	10/15
5.9	Acceleration time with/without load (over 10 m)		[s]	4,9/4,6	TBA	5,0/4,6	TBA
5.10	Service brake			Electric	Electric	Electric	Electric
ELECTRIC MOTOR							
6.1	Drive motor rating S2 60 min		[kW]	9.0	9.0	9.0	9.0
6.2	Lift motor rating S3 15%		[kW]	11.0	11.0	11.0	11.0
	Lift motor rating S3 15% (High speed version)		[kW]	15.0	15.0	15.0	15.0
6.4	Battery voltage, nominal capacity $K_5$		[V/Ah]	48/310*	48/465*	48/310*	48/465*
6.5	Battery weight		[kg]	510	685	510	685
6.6	Energy consumption acc to EN16796		[kWh/h]	TBA	TBA	2,46	TBA
6.7	Turnover output		[t/h]	TBA	TBA	66,5	TBA
6.8	Energy consumption at turnover output		[kWh/h]	TBA	TBA	2,58	TBA
OTHERS							
8.1	Type of drive control			Variable AC	Variable AC	Variable AC	Variable AC
8.2	Sound level at the driver's ear according to EN 12 053		[dB(A)]	64	64	64	64

<sup>1)</sup> Not in combination with 310 Ah lead acid battery <sup>2)</sup> Measured according to company standard

<sup>3)</sup> Other alternatives are available

All data are based on table configuration. Other configurations may give other values. Truck performance and dimensions are nominal and subject to tolerances. Products and specifications are subject to change without notice.

# CESAB R214 - R216, Coldstore versions

## Dimensional Drawings (2021 Model)

### Battery compartments

DIMENSIONS		R214 Coldstore w/o cabin			R214 Coldstore w. cabin			R216 Coldstore w/o cabin			R216 Coldstore w. cabin	
Battery compartment depth	[mm]	275	347	419	347	419	275	347	419	347	419	
1.8 Load distance, centre of support arm wheel to face of forks	x [mm]	341 <sup>1)</sup>	269 <sup>1)</sup>	190	260	188	341 <sup>1)</sup>	269 <sup>1)</sup>	190	260	188	
4.20 Length to face of forks	$l_2$ [mm]	1263 <sup>2)</sup>	1335 <sup>2)</sup>	1425	1407	1479	1263 <sup>2)</sup>	1335 <sup>2)</sup>	1425	1407	1479	
4.33 Aisle width for pallets 1000x1200 crossways	$A_{st}$ [mm]	2695 <sup>2)</sup>	2750 <sup>2)</sup>	2812	2820	2877	2695 <sup>2)</sup>	2750 <sup>2)</sup>	2812	2820	2877	
4.34 Aisle width for pallets 800x1200 lengthways	$A_{st}$ [mm]	2751 <sup>2)</sup>	2817 <sup>2)</sup>	2890	2889	2955	2751 <sup>2)</sup>	2817 <sup>2)</sup>	2890	2889	2955	
4.35 Turning Radius	$W_o$ [mm]	1604	1604	1604	1667	1667	1604	1604	1604	1667	1667	
6.4 Battery voltage, nominal capacity $K_s$ Lead-acid	[V/Ah]	48/310	48/465	48/620	48/465	48/620	48/310	48/465	48/620	48/465	48/620	
Battery voltage, nominal capacity $K_s$ Li-ion	[V/Ah]	...	48/300-420	48/300-420	48/300-420	48/300-420	...	48/300-420	48/300-420	48/300-420	48/300-420	
6.5 Battery weight, min.—max.	[kg]	510-609	685-825	875-1030	685-825	875-1030	510-609	685-825	875-1030	685-825	875-1030	

<sup>1)</sup> With battery in sleigh - 9 mm <sup>2)</sup> With battery in sleigh + 9 mm

### Mast Dimensions

CESAB R214/216		TRIPLEX FULL FREELIFT A											
Lift height	$h_{23}$ [mm]	4900	5400	5700	6300	7000	7250	7500	8000	8500	9000	9500	10000
4.4 Lift	$h_3$ [mm]	4845	5345	5645	6245	6945	7195	7445	7945	8445	8945	9445	9945
4.2 Height, mast lowered	$h_1$ [mm]	2187	2354	2454	2654	2887	2971	3054	3221	3387	3554	3721	3887
4.3 Free lift	$h_2$ [mm]	1703	1871	1971	2171	2403	2487	2571	2737	2903	3071	3237	3403
4.5 Height, mast extended	$h_4$ [mm]	5440	5941	6241	6841	7540	7792	8041	8542	9040	9541	10042	10540

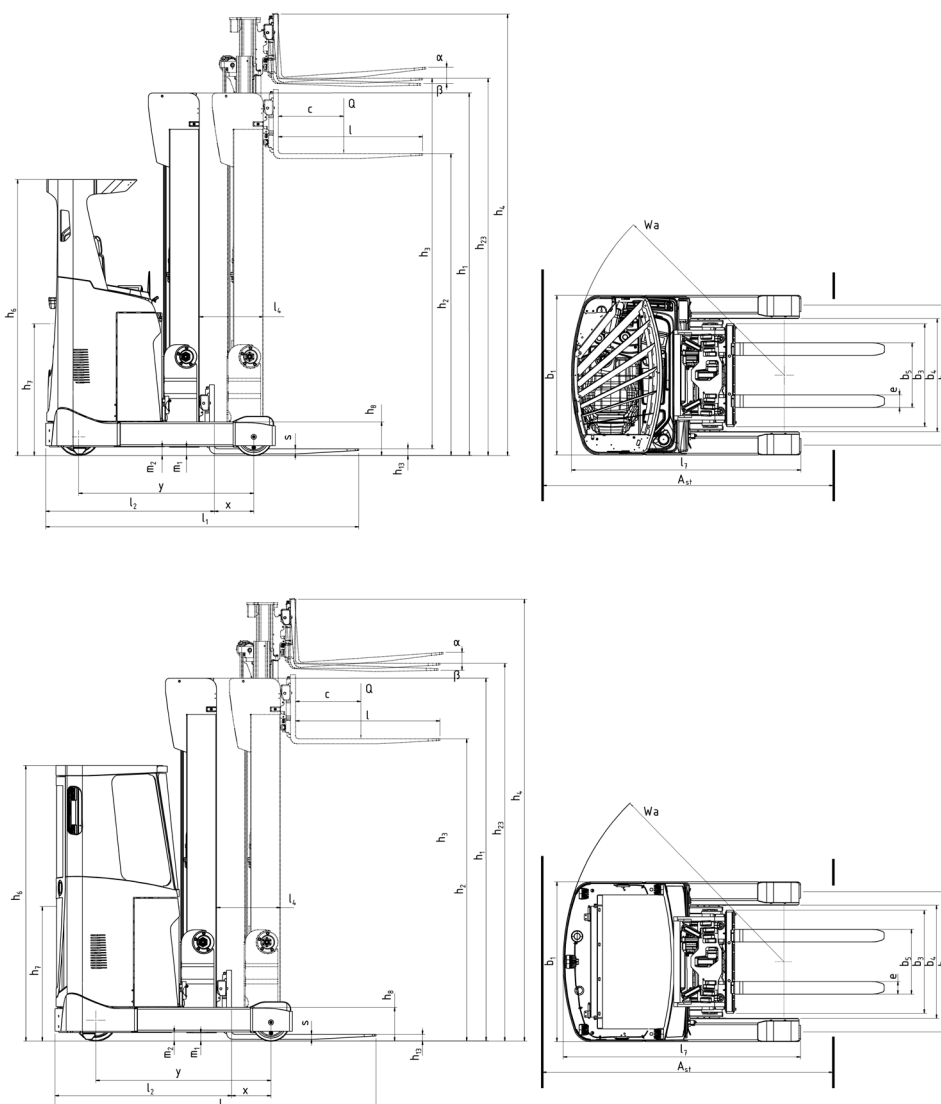



CESAB R200 1.4 - 1.6 tonne

## The CESAB R200 does it better

### The reach truck that fits all your needs

- Load capacities 1.4 and 1.6 tonnes
- Superior all-round visibility for the driver
- Fully adjustable workspace, adaptable to any morphology
- 360° steering for smooth, fast and save material handling
- Optimal Truck Performance: safe use of the full truck potential
- Transitional Lift Control for shockless and fastest lifting and lowering
- Intelligent Mast Design for best visibility and safety
- Digital colour display, an innovative new man-machine interface

### Unique, 900 mm between support arms



The CESAB R200 reach truck offers a unique feature that assures cost savings and capacity increase in your warehouse.

Slim-fit on the outside, only 1120 mm wide, but 900 mm width between the support arm so you can pull an 800 mm Euro-pallet between the support arms without lifting!

The advantages are obvious:

- Less expensive racking as you don't need the lower layer anymore that compensates for the support arm height
- You gain in stocking capacity and win 40 to 50 cm in height
- The driver gains in performance as he has less handling to do to place a pallet

### More comfort for 100% productivity

The driver compartment of the CESAB R200 is fully adjustable and any driver will find a comfortable, optimal drive position.

#### Seat adjustments:

- Forward/backward
- Suspension (weight)
- Backrest angle
- Lumbar support
- Seat cushion length

#### Available seat options:

- Air-suspended version
- Heated version
- Orange seatbelt

#### Steering column adjustments:

- Up and down
- Column angle
- Column length

#### Command console:

- Horizontally
- Vertically

#### Floor board:

- Up and down





## More precision for 100% security

The new steering column has a lower profile to create more space for the driver's knees. The palm support size was increased to avoid fatigue.

Software wise, the system has a higher resolution for more precise manoeuvring and faster response while turning the wheel. Overall, the driver will experience a more responsive and agile CESAB R200

### Optimised Truck Performance

The CESAB R200 features Optimised Truck Performance that regroups three features:

- Optimised corner control that automatically adjusts the drive speed in a curb
- Optimised reach control to avoid mast sway especially at high lift heights
- Optimised speed control with the mast reached out again to avoid mast sway

## The complete package

CESAB'S commitment to creating superior products is matched by its drive to deliver unrivalled service and support. Every CESAB customer benefits from a nationwide network of local dealerships.

Buying a CESAB reach truck is only the beginning of the support from your nearest dealer, with the experienced and fully qualified service engineers only a local call away.



Your authorised CESAB dealer



Pictures may show optional equipment and accessories not included in the standard execution of the truck.

The data in this specification sheet was determined based on our standard testing conditions. Operating performance may vary depending on the actual specification and condition of the truck as well as the condition of the operating area.

Availability and specifications are determined regionally and are subject to change without notice. Please consult your authorised CESAB dealership for further details.  
SPEC\_R200\_EN\_2022 / Ucan V04 – Copyright CESAB Material Handling Europe.

